

UV100A Ultraviolet Air Treatment System

INSTALLATION INSTRUCTIONS

APPLICATION

When installed in forced air heating and cooling systems, the UV100A Ultraviolet Air Treatment System kills airborne micro-organism contaminants in the air passing over it. Individual results depend on how carefully all installation and maintenance requirements are followed and on the actual amount of time the air delivery fan operates.

To capture and minimize micro-organism pass-through in residential heating, ventilation and air conditioning (HVAC) systems, combine the Ultraviolet Air Treatment System with a high-efficiency air filtration system that includes an electronic air cleaner. Add a high-efficiency electronic air cleaner to complement the air treatment system and provide added benefit for the homeowner.

The UV100A Ultraviolet Air Treatment System is available in three models: a single-lamp, entry level medium-efficiency return air unit; a two-lamp, premium high-efficiency return air unit; and an air conditioner coil irradiation unit.

- The UV100A1000 single-lamp, entry level unit is mounted in the return air duct of an HVAC system. It has moderate-efficiency performance against airborne bacteria in return air applications.
- The UV100A1018 two-lamp, premium unit is mounted in the return air duct of an HVAC system. It has high-efficiency performance against airborne bacteria in return air applications.
- The UV100A1026 coil irradiation unit is mounted in the supply side air duct or downstream from the air conditioner cooling coils in the HVAC system. The single lamp reduces mold and spores on duct surfaces, coils and drip pans.

The Ultraviolet Air Treatment System has a power cord that plugs into a 120 Vac electrical outlet. The units are designed to prevent accidental installer and homeowner contact with the voltage and with the ultraviolet rays in the sealed unit—the ultraviolet lamps do not illuminate unless the base is mounted on the HVAC duct.

INSTALLATION

When Installing this Product...

1. Read these instructions carefully. Failure to follow them could damage the product or cause a hazardous condition.
2. Check the rating given in the instructions and on the product to make sure the product is suitable for your application.
3. Installer must be a trained, experienced service technician.
4. After installation is complete, check out product operation as provided in these instructions.



CAUTION

Personal Injury Hazard.

Power supply can cause electrical shock.

Disconnect power supply before beginning installation. Do not open base unit or lamp knob; there are no user-serviceable components inside.



WARNING

UV Light Hazard.

Harmful to skin and eyes.

Can cause temporary or permanent loss of vision.

Never look at the lamps while illuminated.

Only view illumination by way of the light indicator on the lamp knob.

To prevent exposure to ultraviolet light, disconnect power to the ultraviolet air treatment system before servicing any part of the heating/air conditioning system.

Do not mount device in location that allows ultraviolet light to be seen after installation.

Do not attempt to bypass the duct mount switch.

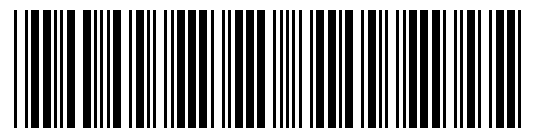

Selecting Mounting Location



CAUTION

Equipment Damage Hazard.
Ultraviolet light can cause color shift or structural degradation of plastic HVAC materials.
 Select mounting location that prevents exposure to plastic flexible duct liner or other plastic components with unknown resistance to ultraviolet light.

NOTE: When the installer is uncertain about whether the drip pan in the installation can tolerate UV exposure, call the Honeywell Customer Assistance Center, 1-800-468-1502, Monday-Friday, 7:00 am to 5:30 pm, Central time. Ask for drip pan testing results.

IMPORTANT

- *The Ultraviolet Air Treatment System units operate outside the duct in residential environments exposed to temperatures between 30° and 120°F (-2° and +49°C).*
 - *The lamp(s) inside the duct operate normally at varying temperatures, depending on the model:*
 - *Single-lamp entry level units can be exposed to temperatures between 30° and 120°F (-2° and +49°C).*
 - *Two-lamp premium unit lamps can be exposed to temperatures between 30° and 120°F (-2° and +49°C).*
 - *Coil irradiation unit lamp can be exposed to temperatures between 30° and 170°F (-2° and +77°C) in moving air and 30° and 120°F (-2° and 49°C) in still air.*
 - *The Ultraviolet Air Treatment System operates normally when exposed to 95 percent relative humidity, non-condensing.*
1. The ultraviolet air treatment system can be mounted in any orientation.
 2. Choose a location that is readily accessible for regular inspection and cleaning.
 3. Allow clearance in front of the device for removing the lamp assemblies. See Fig. 2 for lamp assembly lengths.

4. Select mounting location that prevents exposure to plastic components with unknown resistance to ultraviolet light. A minimum of three feet is required between the ultraviolet lamps and devices fabricated of plastic, such as humidifiers.
5. Mount the ultraviolet air treatment system to non-lined metal ductwork. Do not mount in a location that permits ultraviolet exposure to plastic flexible duct liner.



CAUTION

Sharp Edges Hazard.
Can cause personal injury.

Be careful when inserting ultraviolet device into the sheet metal cutout.
 Wear protective gloves when working near sheet metal.

Mounting in Duct

Use the following instructions to mount the air treatment system on the air duct of an HVAC system:

1. Disconnect power to the HVAC system before installing the Ultraviolet Air Treatment System.
2. Determine the location for installation (see Fig. 1):
 - a. The entry level and premium units require an easily-accessible, flat mounting surface on the metal return air duct of the HVAC system. The coil irradiation unit requires an easily-accessible, flat mounting surface on the metal supply air duct of the HVAC system. The coil irradiation unit must be located so the lamp surrounds the evaporator coil and drip pan with ultraviolet light.
 - b. The duct mounting location must be a minimum of 8 in. wide. See Fig. 2.
 - c. The depth of the duct must accommodate the full length of the ultraviolet lamp for your model as shown in Fig. 2.
 - d. The unit should be located as far away as possible from any rubber or plastic components, such as isolators, in the duct.
 - e. The space adjacent to the mounting location must be large enough to allow for ultraviolet lamp installation and removal.
 - f. A 120 Vac electrical outlet must be within range of the unit to plug in the power cord.

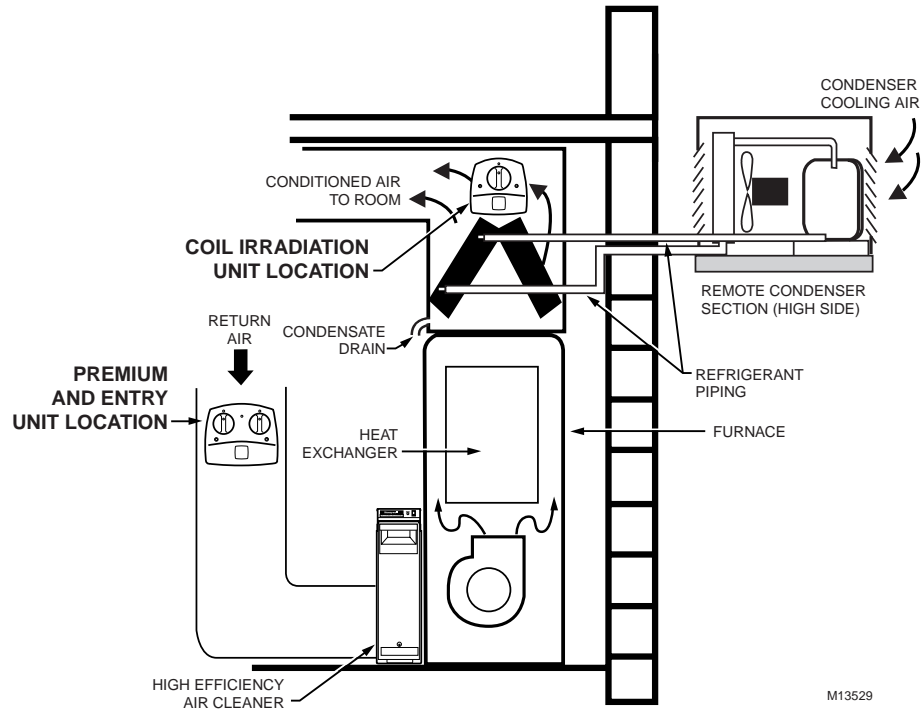

Fig. 1. Selecting mounting location for Ultraviolet Air Treatment System.

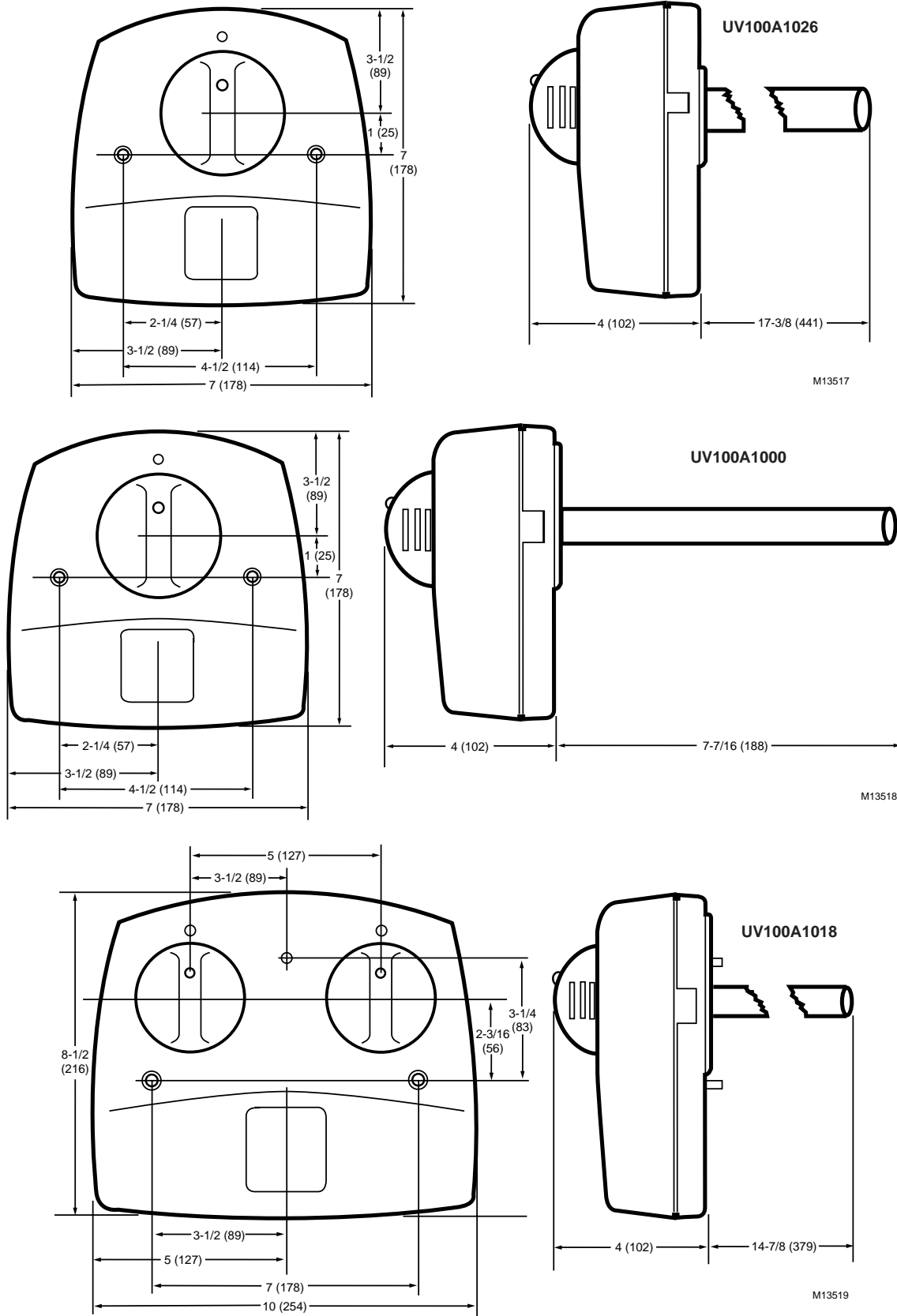

Fig. 2. Ultraviolet Air Treatment System dimensions in in. (mm).

- Place the appropriate template for your model on the duct surface, centering the lamp hole(s) on the duct. See Fig. 3 (below and next page) for the template for your model.

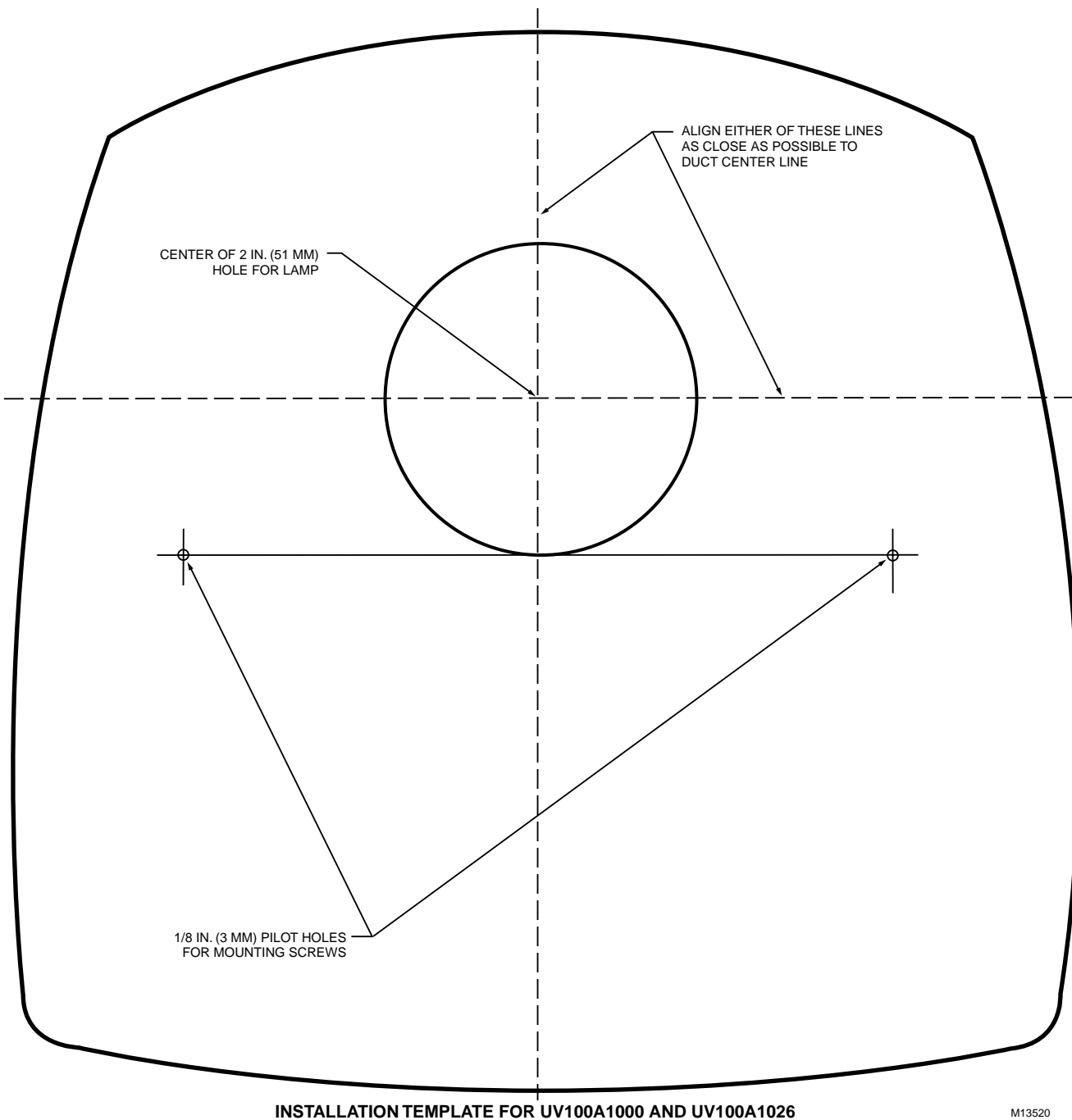
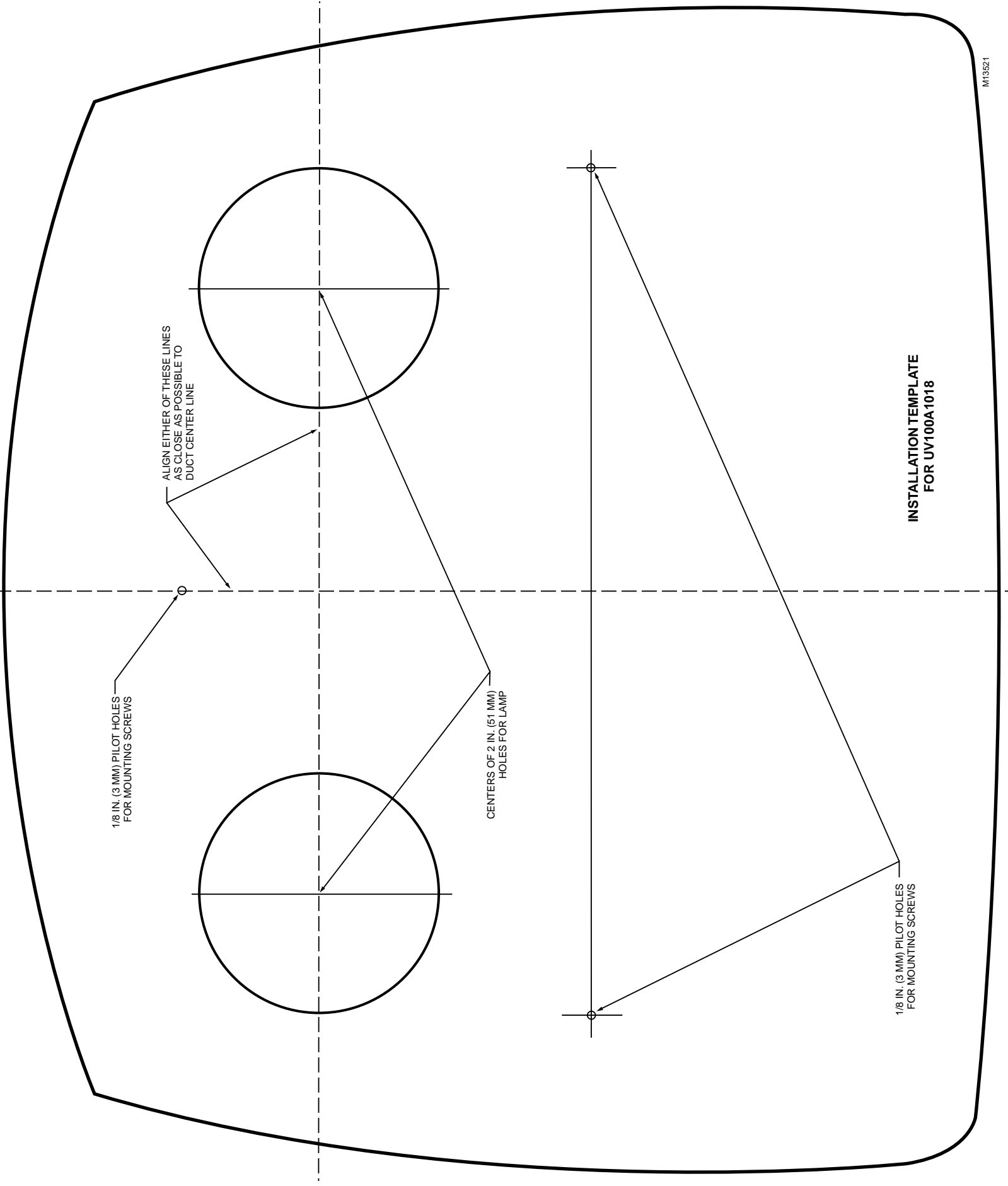

Fig. 3. Ultraviolet Air Treatment System templates.

- Mark the location on the duct for the 2 in. diameter lamp hole(s) and the unit mounting-screw pilot holes.
- Use a 2 in. hole saw to cut the lamp hole(s) in the duct. Remove any burrs.
- Use a 1/8 in. drill to provide pilot holes for the mounting screws.
- Be sure the duct surface is flat after all holes are drilled.
- Position the entire base unit on the duct. Be sure the lamp holes in the duct align with those in the unit to allow lamp insertion.
- Install the unit into the duct using the three (or two, depending on the model) no.10, 2 in. Phillips head sheet metal mounting screws provided. (There is a spare screw provided for the three-screw model.)
- Tighten the screws to 12 to 14 in.-lb so the space between the case and duct is sealed.



1/8 IN. (3 MM) PILOT HOLES
FOR MOUNTING SCREWS

ALIGN EITHER OF THESE LINES
AS CLOSE AS POSSIBLE TO
DUCT CENTER LINE

CENTERS OF 2 IN. (51 MM)
HOLES FOR LAMP

1/8 IN. (3 MM) PILOT HOLES
FOR MOUNTING SCREWS

INSTALLATION TEMPLATE
FOR UV100A1018



CAUTION

**Breakable Glass Hazard.
Can cause personal injury.**

Be careful when inserting lamps(s) into lamp base.
Wear protective gloves when handling lamp(s).



MERCURY NOTICE

This device contains mercury in the sealed ultraviolet lamp(s). Do not place your used lamp(s) in the trash. Dispose of properly.

**Broken Lamp Cleanup.
Do not use a household vacuum.**

Sweep debris (phosphor/glass) into a plastic bag and dispose of properly.

Contact your local waste management authority for instructions regarding recycling and the proper disposal of old lamp(s). For questions, call Honeywell Customer Response Center at 1-800-468-1502.

11. Insert the lamp into the base unit with the lamp light indicator at the eleven o'clock position (left of the raised button on the unit cover). *Do not touch the lamp surface with your hands.*
12. Continue lightly pushing in on the lamp while rotating it slowly counterclockwise. This should cause the lamp to drop into the bottom of the lamp well.
13. Rotate the lamp clockwise until it snaps into place with the lamp indicator light aligned with the raised button on the unit cover.



WARNING

**UV Light Hazard.
Harmful to skin and eyes.
Can cause temporary or permanent loss of vision.**

Never look at the lamps while illuminated.
Only view illumination by way of the light indicator located on the lamp knob.

To prevent exposure to ultraviolet light, disconnect power to the ultraviolet air treatment system before servicing any part of the heating/air conditioning system.

14. Plug the cord into the nearby 120 Vac electrical outlet.
15. Reconnect the power to the HVAC system.
16. Choose a location on the adjacent HVAC equipment for the HVAC maintenance label included in the air treatment system packing box. Choose a location that a future installer can easily see during any future HVAC maintenance or repair.
17. Adhere the HVAC maintenance label to the HVAC equipment (selected in step 16) such as the furnace, air cleaner or humidifier.

CHECKOUT

The installer should verify that the ultraviolet lamp(s) are operating *only by viewing the lamp indicator on the lamp knob. Do not attempt to look directly into the duct to see the illuminated ultraviolet lamps.*

The installer should orient the homeowner to the unit by showing them the blue glow of the lamp indicator and discussing how to determine when the unit is functioning properly without looking directly into the duct to see the illuminated ultraviolet lamps. The installer should also emphasize the hot surface and electrical shock safety warnings.

The installer should leave the Owner's Guide with the homeowner and review the lamp cleaning and lamp replacement procedures. A Lamp Cleaning Schedule is included in the Owner's Guide to help the homeowner set up and track a regular cleaning schedule.

TROUBLESHOOTING AND SERVICE

The Ultraviolet Air Treatment System has no field-serviceable parts. Lamp cleaning is recommended as routine maintenance four times a year or every three months (quarterly). Annual lamp replacement is required. See the Owner's Guide for detailed procedural information.

