

**SST (SUPER SLIM TWIN)  
ELECTRONIC AIR CLEANER**  
High Efficiency Electronic Air Cleaner



**SST Series**

**FEATURES**

- High efficiency electronic design.
- Four standard sizes.
- Easy to install.
- Snap-on power door.
- Twin 5" collecting cells.

**SPECIFICATIONS**

Dimensions . . . . . Refer to bottom of page for rough-in dimensions

Sizing . . . . . See page 196

**PARTS AND ACCESSORIES** See page 198 for additional parts and accessories

- Replacement charcoal filters: Refer to page 198
- F859-0381 – Air Flow Monitor Kit
- F881-0240 – 240 Volt Conversion Kit

**TECHNICAL HELP**

Sizing . . . . . See page 196

Parts view . . . . . See page 198

Electronic Air Cleaner Parts Reference Guide . . . . . See page 211-229



Model Number	CFM	Recommended CFM	A/C Tonnage	BTU Input Range	Power Requirements	Shipping Weight
SST1000-101*	1000	600-1200	up to 3.0	up to 120,000	120 VAC, .3A, 50/60 Hz	42 lbs.
SST1000-151*						
SST1400-101*	1400	1000-1600	up to 4.0	up to 160,000	120 VAC, .3A, 50/60 Hz	46 lbs.
SST1400-151*						
SST1600-101*	1600	1200-1800	up to 4.5	up to 180,000	120 VAC, .3A, 50/60 Hz	46 lbs.
SST1600-151*						
SST2000-101*	2000	1600-2200	up to 5.5	up to 220,000	120 VAC, .3A, 50/60 Hz	48 lbs.
SST2000-151*						

\*-101 Models (No Air Switch)

\*-151 Models (With Air Switch and 6' Electrical Cord)

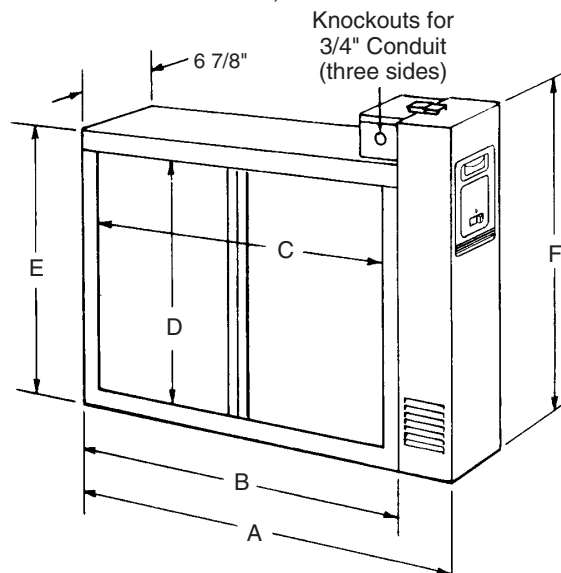

**DIMENSIONAL DATA (-101 and -151 models)**

Model Number	Dimensions in inches					
	A	B	C	D	E	F
SST1000	24 <sup>3</sup> / <sub>4</sub>	21 <sup>5</sup> / <sub>16</sub>	18 <sup>5</sup> / <sub>8</sub>	13 <sup>9</sup> / <sub>16</sub>	16 <sup>7</sup> / <sub>16</sub>	19 <sup>1</sup> / <sub>16</sub>
SST1400	29 <sup>11</sup> / <sub>16</sub>	26 <sup>1</sup> / <sub>4</sub>	23 <sup>5</sup> / <sub>8</sub>	13 <sup>3</sup> / <sub>16</sub>	16 <sup>7</sup> / <sub>16</sub>	19 <sup>1</sup> / <sub>16</sub>
SST1600	25 <sup>1</sup> / <sub>2</sub>	21 <sup>5</sup> / <sub>16</sub>	18 <sup>5</sup> / <sub>8</sub>	17 <sup>3</sup> / <sub>4</sub>	20 <sup>5</sup> / <sub>8</sub>	23 <sup>3</sup> / <sub>8</sub>
SST2000	29 <sup>11</sup> / <sub>16</sub>	26 <sup>1</sup> / <sub>4</sub>	23 <sup>5</sup> / <sub>8</sub>	17 <sup>3</sup> / <sub>4</sub>	20 <sup>5</sup> / <sub>8</sub>	23 <sup>3</sup> / <sub>8</sub>