

Electro-air
ELECTRONIC AIR CLEANERS

UST TECH SHEET

REPAIR PARTS ILLUSTRATION

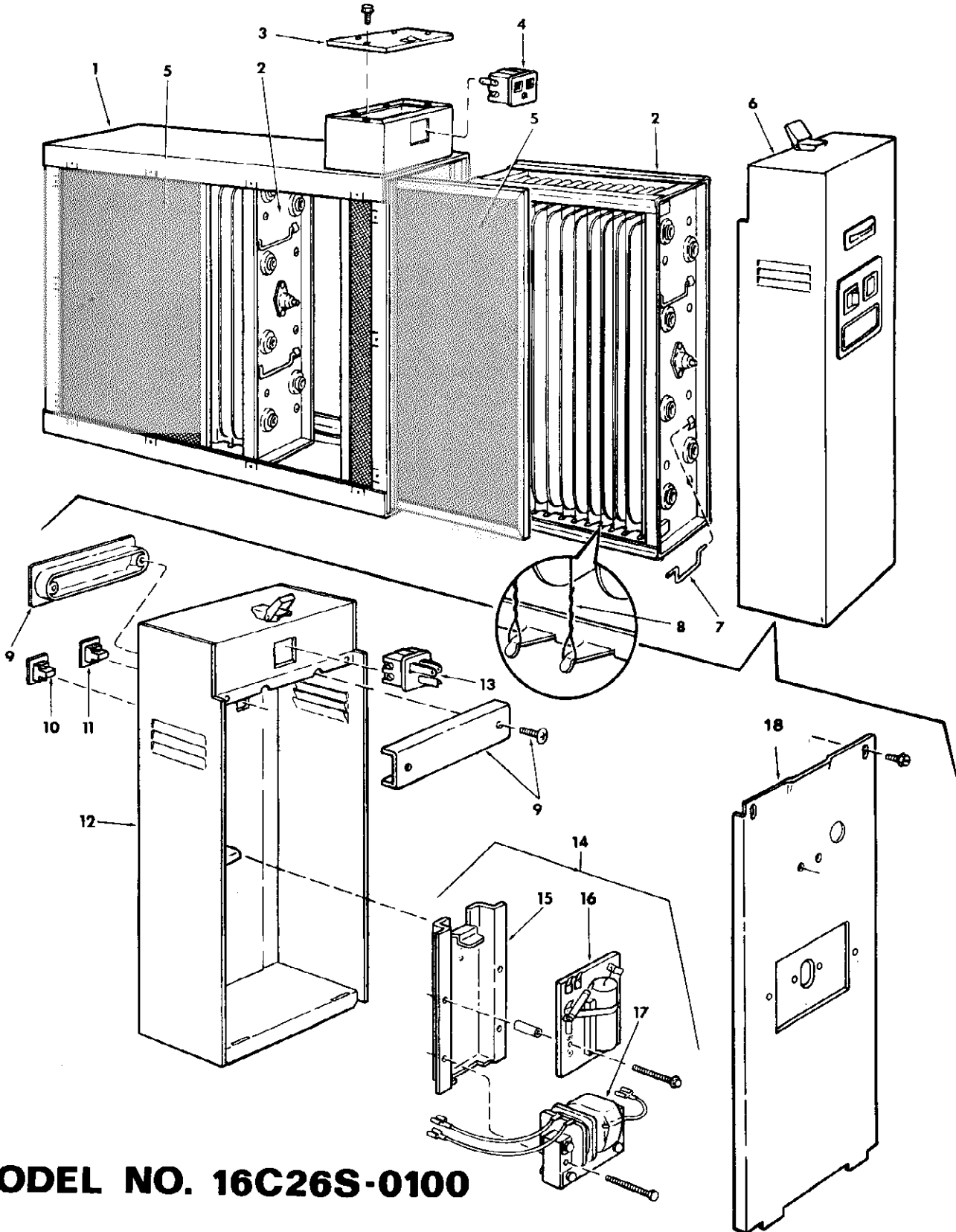

MODEL NO. 16C26S-0100

INTRODUCTION

ELECTRO-AIR TECH REPAIR SHEET

MODEL NO. 16C26S-0100

This sheet contains service checks to assist service personnel in locating and correcting any malfunction that might occur to render the air cleaner ineffective or inoperative. The air cleaner has been designed with replaceable components, such as the high-voltage transformer, high-voltage component board and air flow monitor, which allows the serviceman to simply replace a defective component rather than attempt repairs of such components in the field.

The first chart "Basic Service Guide" will probably cover many owner complaints. If after checking the items listed, the air cleaner still fails to operate properly, continue with the second chart "Complete Checkout Procedure" until the trouble has been located. (See wiring diagram)

CAUTION:

This Tech Sheet was designed to be used only by personnel qualified to recognize shock hazards and those trained in the repair of electronic air cleaners. These instructions are not implied to be adequate to ensure safe usage by non-qualified personnel.

NORMAL OPERATION

ON/OFF switch light "ON"; Operating Light "ON"

- Voltage on air cleaner cell/s; either ionizer or plates 6200 to 7100 V.D.C.
- Voltage at power pack cell contact with no cells attached (open circuit) 7,000 to 8,500 VDC.

BASIC SERVICE GUIDE

| SERVICE INDICATION | SERVICE CHECKS |
|--|--|
| ON/OFF switch light "ON" Operating light "ON" | Power is being supplied to the air cleaner, unit functioning properly. |
| ON/OFF switch light "OFF" Operating light "OFF" | Power is not being supplied to air cleaner. A. Make sure air system fan is operating. B. Check for voltage at air cleaner junction box. If none, check fuse or circuit breaker at 120 VAC input line. C. Check ON/OFF switch which must be in "ON" position. |
| ON/OFF switch light "ON" Operating light "flickering" | A. Remove cell/s and wash thoroughly. B. Check cell/s for any foreign object that might be lodged between plates of cell. C. Check cell/s for broken ionizing wires, cracked insulator, or bent plates. D. When replacing cell/s in cabinet ensure that the directional arrow on cells corresponds with direction of air flowing through air cleaner. Cell contacts must point toward power pack. |
| ON/OFF switch light "ON" Operating light "OFF" | Remove power pack from air cleaner cabinet. Using a standard extension cord, apply 120 VAC to power pack. A. If operating light comes "ON" problem is in collecting cell/s. Recheck. B. If operating light remains "OFF" malfunction is in the power pack. Continue with "complete checkout procedure." |
| ON/OFF switch light "ON" Operating light "flickering". Cell/s "arcing" excessively. | A. Check voltage at air cleaner junction box. Voltage should not exceed 120 VAC. Note: Air cleaner should not be wired to fan motor taps. B. Remove cell/s and wash thoroughly. IMPORTANT: All ionizing wires must be completely clean with no build-up on wires. |

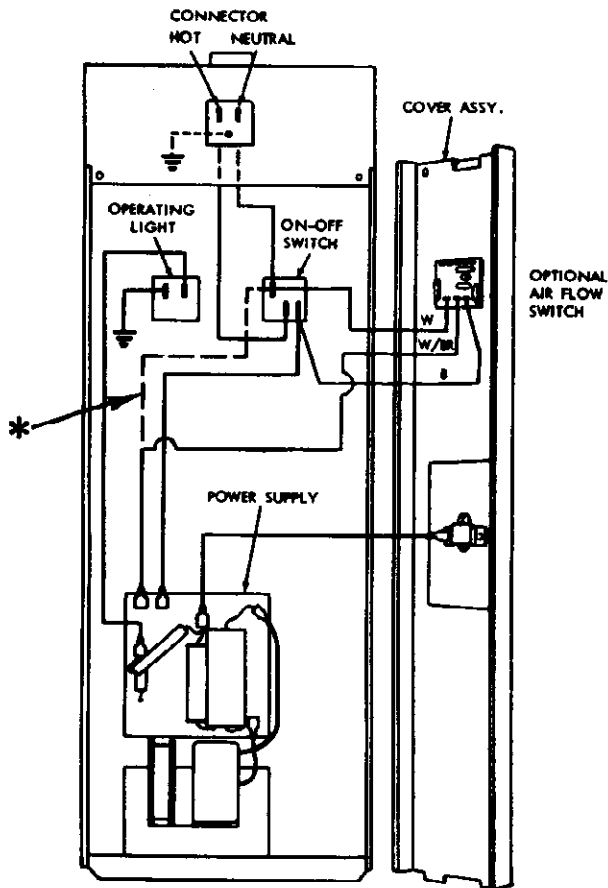

* REMOVE NEUTRAL WIRE FROM POWER SUPPLY TO ON-OFF SWITCH WHEN INSTALLING OPTIONAL AIR FLOW MONITOR.

Fig. 1

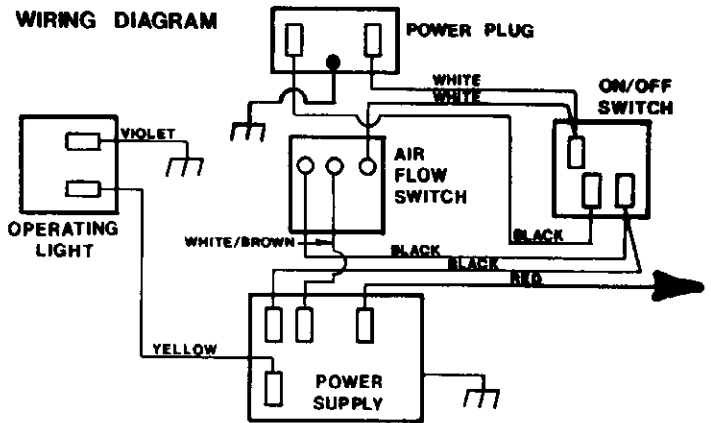

NOTE: When servicing, wiring should be routed per factory specifications.

Fig. 2

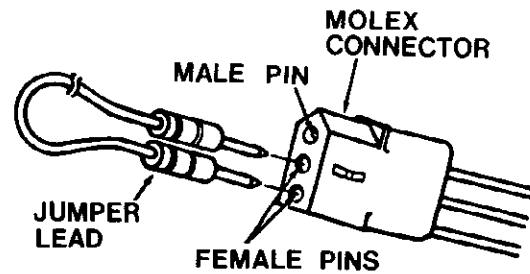

Alternate method for jumping lead wires of connector plug from airflow-switch. This lead should be made locally.

Fig. 3

COMPLETE CHECKOUT PROCEDURE

If the malfunction has not been eliminated in the "Basic Service Guide" proceed to the "Checkout Chart" to locate the problem. When the defective component is discovered and replaced, the air cleaner will resume normal operation.

All voltage measurements indicated can be made with a high voltage D. C. probe and a general purpose volt-ohm meter. For example: Simpson 260 or equivalent.

For testing the UST Power Pack the air flow monitor may be "wired out" of the system. This will eliminate the need of air flow across the face of the monitor. This is accomplished as follows: Using a well insulated jumper wire equipped with a small alligator clip on each end, jumper from the air flow monitor "white/brown terminal" to the air flow monitor "white wire terminal". This jumper replaces wire marked "remove" in wiring diagram. An alternate method of wiring out the air flow monitor is shown in Fig. 3, Page 4.

CHECKOUT CHART

CONDITION I

ON/OFF switch light "OFF"; Operating light "OFF"

1. Check fuse or circuit breaker, check for 120 VAC at air cleaner junction box.
2. If air cleaner is equipped with an air flow monitor, fan must be running and air moving through unit.
3. Remove power pack. Using a standard extension cord apply voltage to power pack from 120 VAC source.
4. Check the following points inside power pack for 120 VAC:
 - A. ON/OFF switch: across black and white wires.
 - B. Power supply: across terminals marked "LINE".
5. If reading of 120 VAC does not appear at all points (Step 4) check primary circuit wiring. If correct, replace ON/OFF switch.

CONDITION II

ON/OFF Switch Light "ON"; Operating Light "OFF"

1. Check collecting cell/s for foreign object between plates; broken ionizing wires; bent plates. Wash cells if required.
2. Check voltage at collecting cell. Voltage should be 6200 to 7100 VDC. If voltage is below 6200 VDC disconnect collecting cell/s.
3. Check voltage at power pack cell contact. Open circuit voltage should be 7,000 to 8,500 VDC.
4. If voltage at cell contact is 7,000 VDC or above problem is in collecting cells. Recheck in accordance with section "Cell Test".
5. If voltage at cell contact is below 7,000 VDC, problem is in power pack. Turn off power and remove back panel.
6. Apply 120 VAC to power pack and measure voltage at terminals marked "LINE". Voltage should be the same as that applied.
7. Check voltage output at terminal marked "light" (lamp) on D. C. Power Supply. DO NOT DISCONNECT LIGHT WIRE FROM TERMINAL. Voltage should be 60 to 100 VDC.
 - A. If voltage to light is 60 VDC or above, replace operating light.
 - B. If voltage to light is below 60 VDC, refer to Section "Power Supply Test".

POWER SUPPLY TEST

1. Check power supply input voltage at terminals marked "LINE". Voltage should be 120 VAC. If there is no voltage at "LINE" terminals problem is in primary voltage circuit.
2. Remove power supply from power pack. Check all terminals and wires for tightness.
3. Test transformer by either or both methods.

TRANSFORMER TEST (RESISTANCE)

- A. Measure resistance of transformer primary coil through terminals marked "LINE". Resistance should be 30 to 50 ohms.
- B. Disconnect transformer secondary leads from H. V. Component Board and measure resistance of Secondary Coil. Resistance should be 8,000 to 12,000 ohms.
- C. If resistance reading of either coil is out of tolerance replace transformer, if not replace component board.

TRANSFORMER TEST (VOLTAGE)

- A. Disconnect transformer secondary leads from H. V. Component Board and attach a multimeter set to read 2000 VAC to leads. Apply 120 VAC to terminals marked "LINE".
- B. If output is below 1000 VAC, replace transformer.
- C. If output is above 1000 VAC, replace component board.

CELL TEST

1. Place collecting cell on a well insulated work bench with the cell contact button pointing upward.
2. Select a UST Power Pack that reads between 7,000 and 8,500 VDC at the cell contact in an open circuit mode.
3. Place the UST Power Pack on top of the collecting cell ensuring that there is proper contact between the cell contact and the power pack contact.
4. Using a standard extension cord apply 120 VAC to power pack. Turn ON/OFF switch "ON".
5. Measure voltage at collecting cell ionizer or cell plates. Voltage should be 6200 to 7100 VDC.
 - A. If voltage is above 6200 VDC test other cell (if applicable.)

- B. If voltage is below 6200 VDC check cell as prescribed in Step # 1, Condition # II.

NOTE: When replacing collecting cell/s in cabinet ensure that the arrows on cell/s point in the same direction as the air flow through ductwork. To reverse air flow turn cell/s upside down. Cell contact buttons must point toward the power pack.

AIR FLOW MONITOR TEST

1. Connect a multimeter set to read 120 VAC to power supply terminals marked "LINE".
2. Connect 120 VAC to power pack plug, turn ON/OFF switch "ON".
3. Blow on thermister at air flow monitor. 120 VAC should appear at multimeter. Stop blowing and voltage should disappear in 10-15 seconds.
4. If voltage did not appear (Step 3) disconnect power to power pack. Install an insulated jumper from terminal of "white" air flow monitor wire to terminal of the "white/brown" air flow monitor wire. Reconnect power to power pack.
 - A. If 120 VAC appears at multimeter, replace air flow monitor.
 - B. If 120 VAC does not appear on multimeter problem is other than air flow monitor. Recheck all primary wiring.

NOTE: The air flow monitor is designed to operate in the temperature range of 32° to 120°F. Operation outside this range is not recommended.

In the event that the problem has not been corrected by using the procedures outlined on this Tech Repair Sheet, then contact

Service Manager
Electro-air Division
Emerson Electric Company
North Industrial Park Road
Harrison, Arkansas 72601
Phone (501) 741-3464

PARTS LIST

ELECTRONIC AIR CLEANER MODEL NO. 16C26S-0100

WHEN ORDERING REPAIR PARTS, ALWAYS GIVE THE FOLLOWING INFORMATION AS SHOWN IN THIS LIST.

1. The PART NUMBER
2. The PART DESCRIPTION
3. The MODEL NUMBER
4. The NAME OF ITEM — Electronic Air Cleaner

Always Order by "Part Number" . . . Never by "Item No."

| ITEM NO. | DESCRIPTION | Part Number |
|----------|---|-------------|
| 1 | Cabinet Assembly | F808-0554 |
| 2 | Cell Assembly (2 Reg.) | F811-0321 |
| 3 | Cover Assembly | F838-0071 |
| 4 | Connector, Female | F818-0053 |
| 5 | Pre-filter (2 Reg.) | F825-0337 |
| 6 | Power Pack Assembly | F858-0690 |
| 7 | Handle, Cell | F832-0039 |
| 8 | Ionizing Wire | F843-0500 |
| 9 | Handle (with Screws and support) | F832-0030 |
| 10 | Light, Operating | F844-0102 |
| 11 | Switch, On-Off | F876-0160 |
| 12 | Cabinet Assembly, Power Pack | F858-0689 |
| 13 | Connector, Male | F827-0026 |
| 14 | Power Supply Assembly (includes items 15, 16, 17) | F858-0448 |
| 15 | Bracket | F806-0436 |
| 16 | P.C. Board Assembly | F859-0227 |
| 17 | Transformer (with screws) | F881-0175 |
| 18 | Cover, Power Pack | F820-0220 |
| + | Manual | F846-0257 |

+ Not Shown.

WHITE-RODGERS



White-Rodgers Division, Emerson Electric Co.
9797 Reavis Road, St. Louis, MO 63123
(314) 577-1300



Form No. 846-0542